

The Kathrein-Scala RY series are rugged broadband yagi antennas housed in rugged fiberglass radomes, fabricated of 6061/T6 aluminum rod and seamless drawn pipe, anodized for maximum reliability and corrosion resistance. The radome protects the antenna against snow, ice and other adverse environmental conditions which can degrade performance and cause damage. The hardware and fastenings are stainless steel. The internal balun, coax feed and connector are sealed in a foam potting system to prevent moisture penetration and assure long service life in severe environmental conditions. The heavy aluminum mounting casting allows installation for V or H polarization.

- The RY-840B is specifically designed for trunking and other fixed-station applications in the 806–869 MHz band.



(Shown vertically polarized)

Specifications:

Frequency range	806–869 MHz
Gain	12 dBi
Impedance	50 ohms
VSWR	< 1.5:1 maximum (1.35:1 typical)
Polarization	Horizontal or vertical
Front-to-back ratio	>18 dB
Maximum input power	100 watts (at 50°C)
H-plane beamwidth	58 degrees (half-power)
E-plane beamwidth	48 degrees (half-power)
Connector	N female
Weight	16.0 lb (7.3 kg)
Dimensions	29 x 17 x 12 inches (737 x 432 x 305 mm)
Wind load at 93 mph (150kph)	
Side/Top/Rear	63 lbf / 16 lbf / 37 lbf (279 N) / (69 N) / (164 N)
Wind survival rating*	120 mph (200 kph)
Shipping dimensions	31 x 20 x 14.5 inches (787 x 508 x 368 mm)
Shipping weight	28.0 lb (12.7 kg)
Mounting	Mounting kits available for masts of 2.375 to 4.5 inch (60 to 114 mm) OD.

See reverse for order information.

* Mechanical design is based on environmental conditions as stipulated in TIA-222-G-2 (December 2009) and/or ETS 300 019-1-4 which include the static mechanical load imposed on an antenna by wind at maximum velocity. See the Engineering Section of the catalog for further details.

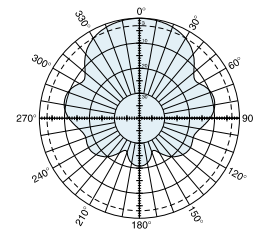

H-plane
Horizontal pattern – V-polarization
Vertical pattern – H-polarization

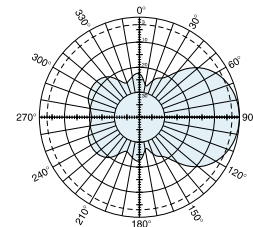

E-plane
Horizontal pattern – H-polarization
Vertical pattern – V-polarization



10057-H



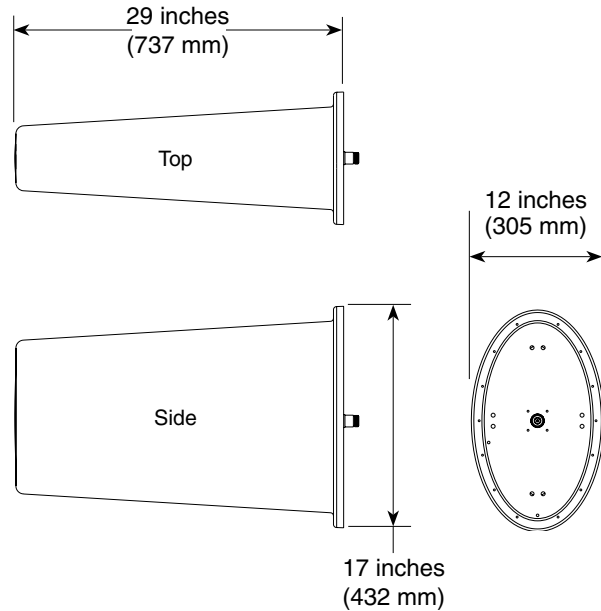
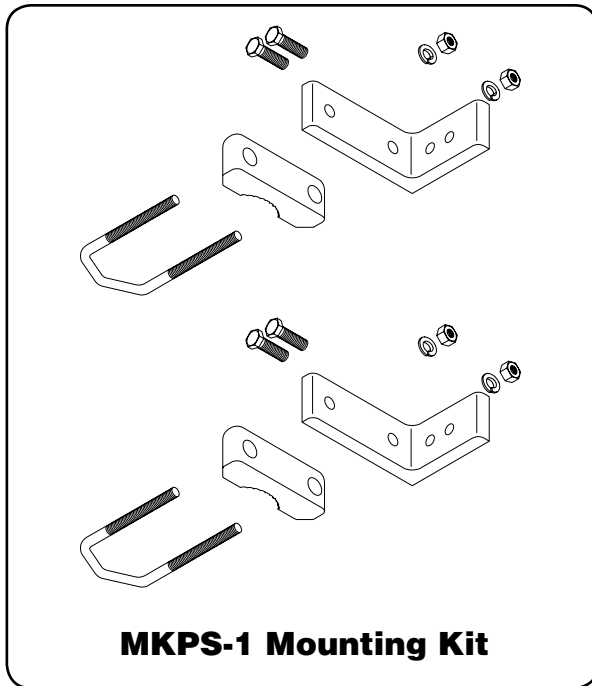

Mounting Options:

Model	Description
MKPS-1	Mounting Kit for 2.375 inch (60 mm) OD mast.
MKPS-2	Mounting Kit for 2.875 inch (73 mm) OD mast.
MKPS-3	Mounting Kit for 3.5 inch (89 mm) OD mast.
MKPS-4	Mounting Kit for 4 inch (102 mm) OD mast.
MKPS-5	Mounting Kit for 4.5 inch (114 mm) OD mast.

Order Information:

Model	Description
RY-840B	Radome protected yagi antenna with N connector

All specifications are subject to change without notice. The latest specifications are available at www.kathrein-scala.com.

Kathrein Inc., Scala Division Post Office Box 4580 Medford, OR 97501 (USA) Phone: (541) 779-6500 Fax: (541) 779-3991
Email: communications@kathrein.com Internet: www.kathrein-scala.com