

The Kathrein Scala Division RA5-400B broadband dipole antenna is intended for use in professional fixed-station applications in the 406–512 MHz band. It features:

- Heavy-duty fiberglass radome to protect antenna.
- Balanced driven element for superior performance in icing conditions.
- Internal balun and dipole feedpoint sealed within the boom assembly.
- Anodized 6061-T6 aluminum tubing.
- Heavy-duty aluminum castings and stainless steel hardware.
- Entire antenna at DC ground potential.
- Dual and quad arrays available.



(Shown vertically polarized)

Specifications:

Frequency range	406–512 MHz in 6 MHz segments
Gain	12 dBi
Impedance	50 ohms
VSWR	<1.3:1 ± 1 MHz <1.5:1 ± 3 MHz
Polarization	Horizontal or vertical
Front-to-back ratio	>23 dB
Maximum input power	250 watts (at 50°C)
H-plane beamwidth	66 degrees (half-power)
E-plane beamwidth	50 degrees (half-power)
Connector	N female
Weight	22 lb (10 kg)
Dimensions	29 x 17 x 12 inches (737 x 432 x 305 mm)
Wind load	at 93 mph (150kph)
Side/Top/Rear	63 lbf / 16 lbf / 37 lbf (279 N) / (69 N) / (164 N)
Wind survival rating*	120 mph (200 kph)
Shipping dimensions	31 x 20 x 14.5 inches (787 x 508 x 368 mm)
Shipping weight	28.0 lb (12.7 kg)
Mounting	Mounting kits available for masts of 2.375 to 4.5 inch (60 to 114 mm) OD.

* Mechanical design is based on environmental conditions as stipulated in TIA-222-G-2 (December 2009) and/or ETS 300 019-1-4 which include the static mechanical load imposed on an antenna by wind at maximum velocity. See the Engineering Section of the catalog for further details.

Contact Kathrein Kathrein Scala Division Division Customer Service for detailed order information.

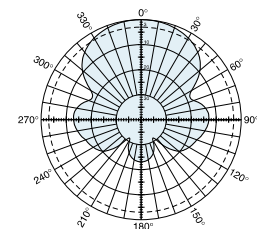

H-plane
Horizontal pattern – V-polarization
Vertical pattern – H-polarization

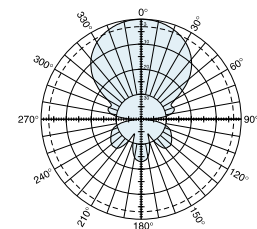

E-plane
Horizontal pattern – H-polarization
Vertical pattern – V-polarization



10105-F

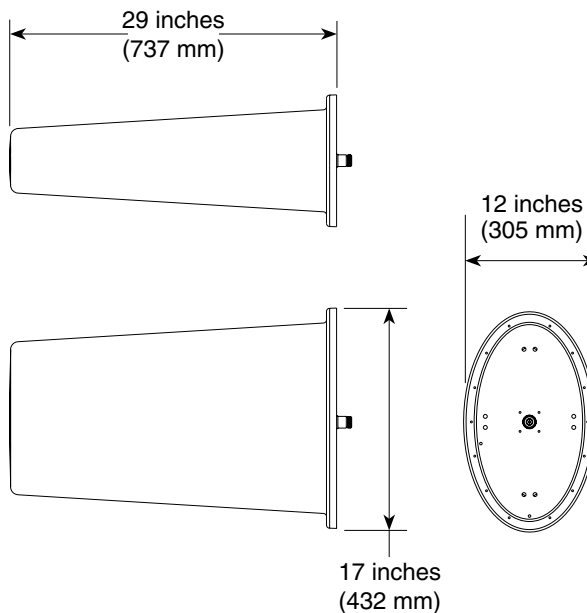
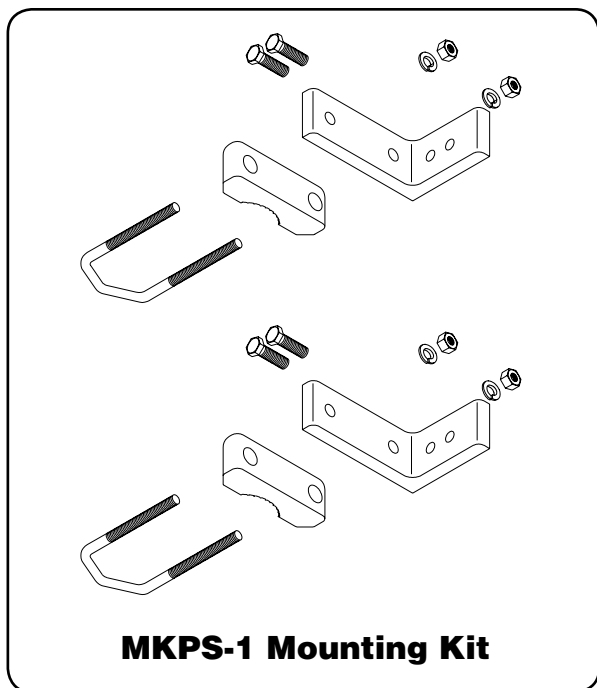

Mounting Options:

Model	Description
MKPS-1(shown)	Mounting Kit for 2.375 inch (60 mm) OD mast.
MKPS-2	Mounting Kit for 2.875 inch (73 mm) OD mast.
MKPS-3	Mounting Kit for 3.5 inch (89 mm) OD mast.
MKPS-4	Mounting Kit for 4 inch (102 mm) OD mast.
MKPS-5	Mounting Kit for 4.5 inch (114 mm) OD mast.

Order Information:

Contact Kathrein Scala Division Customer Service for detailed order information.

All specifications are subject to change without notice. The latest specifications are available at www.kathrein-scala.com.

Kathrein Inc., Scala Division Post Office Box 4580 Medford, OR 97501 (USA) Phone: (541) 779-6500 Fax: (541) 779-3991
Email: communications@kathrein.com Internet: www.kathrein-scala.com