

CA2

VHF-TV DIPOLE REFLECTOR ANTENNA

4 dBd gain
54 to 216 MHz (Channels 2–13)

The Scala CA2 is a ruggedly built dipole reflector antenna, designed for professional VHF-TV transmit and receive applications.

Like all Scala antennas, the CA2 is made of the finest materials resulting in superior performance and long service life.

The CA2 may be used stand-alone or in stacked arrays for higher gain, increased side-lobe suppression, or custom azimuth patterns.



Specifications:

Frequency range	Any specified VHF-TV channel 2–13 54 to 216 MHz
Gain	4 dBd
Impedance	50 or 75 ohms
VSWR	< 1.5:1
Polarization	Horizontal
Front-to-back ratio	>11 dB
Maximum input power	250 watts
Azimuth pattern	72 degrees (half-power)
Elevation pattern	80 degrees (half-power)
Connector	50Ω or 75Ω N female
Weight	14 lb (6.4 kg)
Dimensions	48.5 x 112.3 inches maximum (1232 x 2852 mm)
Equivalent flat plate area	2.2 ft ² (0.204 m ²) maximum
Wind survival rating*	120 mph (193 kph)
Shipping dimensions	110 x 6 x 5 inches maximum (2794 x 152 x 127 mm)
Shipping weight	17 lb (7.7 kg) maximum
Mounting	For masts of 2.375 inches (60 mm) OD.

*Mechanical design is based on environmental conditions as stipulated in EIA-222-F (June 1996) and/or ETS 300 019-1-4 which include the static mechanical load imposed on an antenna by wind at maximum velocity. See the Engineering Section of the catalog for further details.

Order Information:

Contact Scala Customer Service for detailed order information.

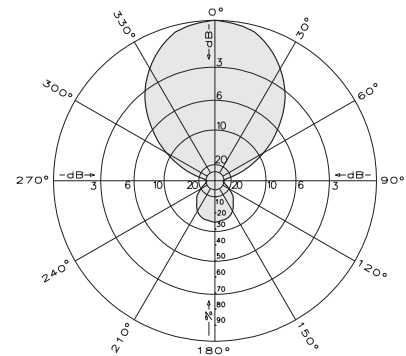

Azimuth pattern (E-plane - typical)

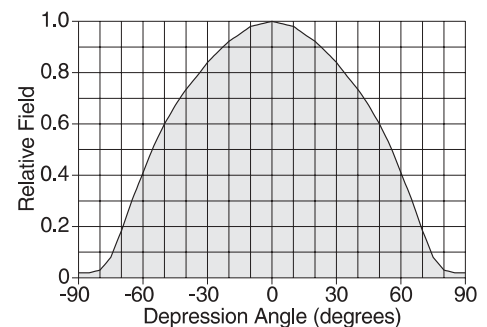

Elevation pattern (H-plane)



10742-A

CA2
VHF-TV DIPOLE REFLECTOR ANTENNA
4 dBd gain
54 to 216 MHz (Channels 2-13)

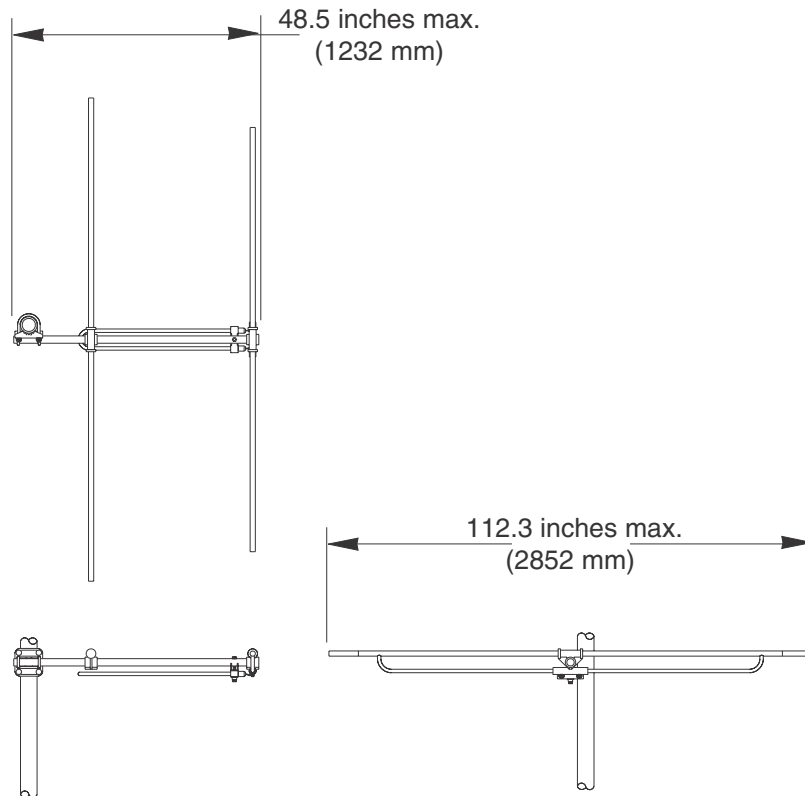

Order Information:

Contact Scala Customer Service for detailed order information.

All specifications are subject to change without notice