

- X-polarized (+45° and -45°).
- UV resistant fiberglass radomes.
- Wideband vector dipole technology.
- DC Grounded metallic parts for impulse suppression.
- RET motor housed inside the radome and field replaceable.

General specifications:

Frequency range	698–894 MHz
VSWR	<1.5:1
Impedance	50 ohms
Intermodulation (2x20w)	IM3: <-150 dBc
Polarization	+45° and -45°
Maximum input power	500 watts per input (at 50°C)
Connector	2 x 7-16 DIN female (long neck) (bottom mounted)
Isolation	>30 dB
Electrical downtilt	0–10 degrees (continuously adjustable)
<i>See reverse for order information.</i>	

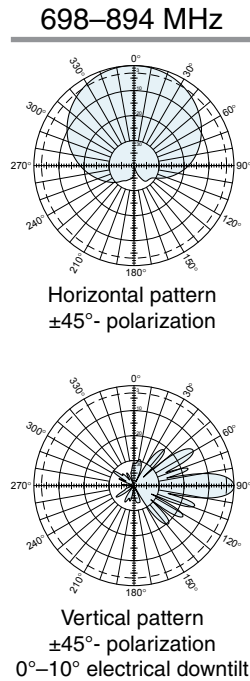

Specifications:

	698–806 MHz	824–894 MHz
Gain	15.5 dBi	16 dBi
Front-to-back ratio	>30 dB (co-polar) 35 dB (average)	>30 dB (co-polar) 35 dB (average)
+45° and -45° polarization horizontal beamwidth	67° (half-power)	65° (half-power)
+45° and -45° polarization vertical beamwidth	11.3° (half-power)	10° (half-power)
Min. sidelobe suppression for first sidelobe above main beam average	0° 5° 10° T 16 17 17 dB 16 19 20 dB	0° 5° 10° T 18 17 16 dB 20 20 20 dB
Cross polar ratio		
Main direction 0°	25 dB (typical)	25 dB (typical)
Sector ±60°	>11 dB, Average: 15 dB	>11 dB, Average: 15 dB

IRT specifications:

Logical interface ex factory ¹	3GPP/AISG 2.0
Protocols	AISG 1.1 and 3GPP/AISG 2.0 compliant
Hardware interface ²	2 x 8 pin connector acc. IEC 60130-9; according to AISG: – IRT in (male): Control / Daisy chain in – IRT in (female): Daisy chain out
Power supply	10–30 V
Power consumption	<1 watt (standby) <8.5 watts (motor activated)
Adjustment time (full range)	40 sec.
Adjustment cycles	>50,000
Certification	FCC 15.107 Class B Computing Devices

¹) The protocol of the logical interface can be switched from 3GPP/AISG 2.0 to AISG 1.1 and vice versa with a vendor specific command. Start-up operation of the RCU 86010149 is possible in an RET system supporting AISG 1.1 or supporting 3GPP/AISG 2.0 after performing a layer 2 reset before address assignment. The protocol can also be changed as follows: AISG 1.1 to 3GPP: Enter "3GPP" into the additional data field "Installer's ID" and perform a layer 7 reset or a power reset. 3GPP to AISG 1.1: Enter "AISG 1" into the additional datafield "Installer's ID" and perform a layer 2 reset or a power reset. After switching the protocol any other information can be entered into the "Installer's ID" field.

²) The tightening torque for fixing the connector must be 0.5 – 1.0 Nm ('hand-tightened'). The connector should be tightened by hand only!



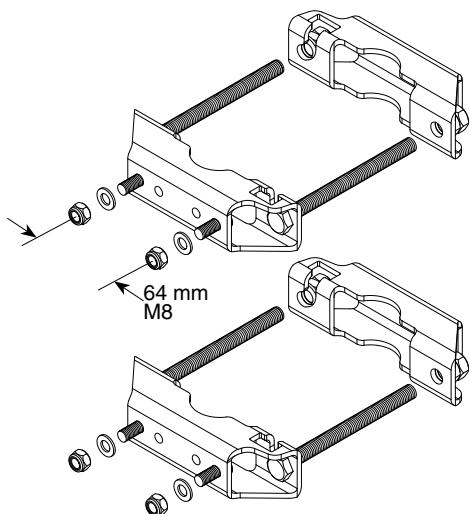

Mounting Brackets

for use with 2-point mount antennas
Mast dia. 2–4.5 inches (50–115 mm)
Weight: 4.4 lb (2 kg)

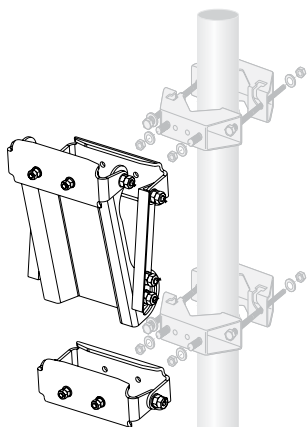

Mechanical Tilt Brackets

for use with 2-point mount antennas
Weight: 13 lb (5.9 kg)
(Model 850 10007)

Mechanical specifications:

Weight	28.7 lb (13 kg)	33.1 lb (15 kg) clamps included
Dimensions	H x W x D	76.1 x 11.9 x 3.9 inches (1934 x 303 x 99 mm)
Wind load	at 93 mph (150kph)	
Front/Side/Rear	203 lbf / 70 lbf / 232 lbf (900 N / 310 N / 1030 N)	
Mounting category	H (Heavy)	
Wind survival rating*	150 mph (240 kph)	
Shipping dimensions	81.1 x 12.4 x 4.5 inches (2060 x 315 x 115 mm)	
Shipping weight	37.5 lb (17 kg)	
Mounting bracket	2-point hot-dip galvanized with stainless steel hardware for 2 to 4.5 inch (50 to 115 mm) OD masts.	

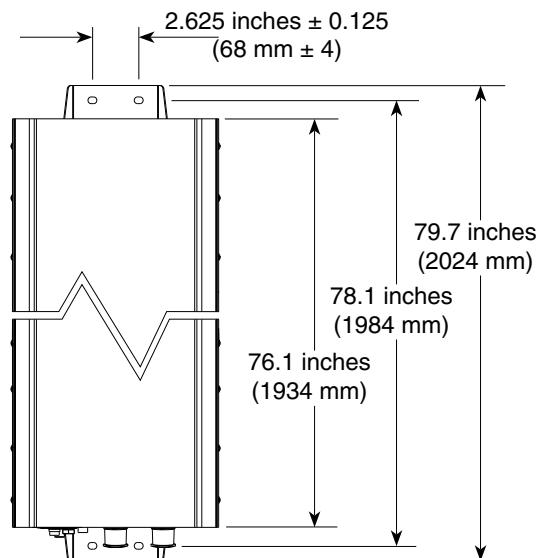

KATHREIN 860 10149

FC Tested To Comply With FCC Standards

This device complies with part 15 of the FCC Rules. Operation is subject to the following two conditions: (1) This device may not cause harmful interference, and (2) this device must accept any interference received, including interference that may cause undesired operation.

Note: Refer to part number 860 10149 for the specifications of the remote control actuator.

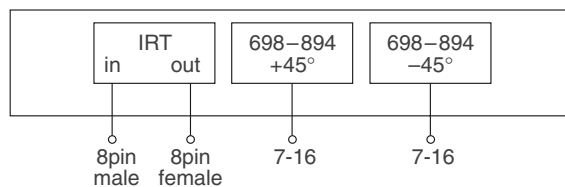
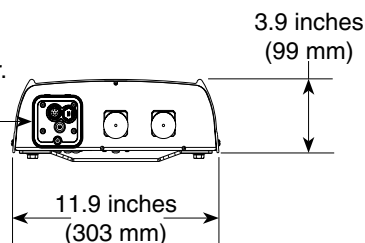

Order Information:

Model	Description
800 10735V01	Antenna with mounting bracket 0°–10° electrical downtilt
800 10735V01K	Antenna with mounting bracket and mechanical tilt bracket 0°–10° electrical downtilt

*Mechanical design is based on environmental conditions as stipulated in TIA-222-G-2 (December 2009) and/or ETS 300 019-1-4 which include the static mechanical load imposed on an antenna by wind at maximum velocity. See the Engineering Section of the catalog for further details.

All specifications are subject to change without notice. The latest specifications are available at www.kathrein-scala.com.